

MILITARY VEHICLES



Movement that inspires

Kia Special Vehicle

<http://military.kia.com>

KLTV

Armored Personnel Carrier

Great mobility, High protection Multi-Role Light Tactical Vehicle

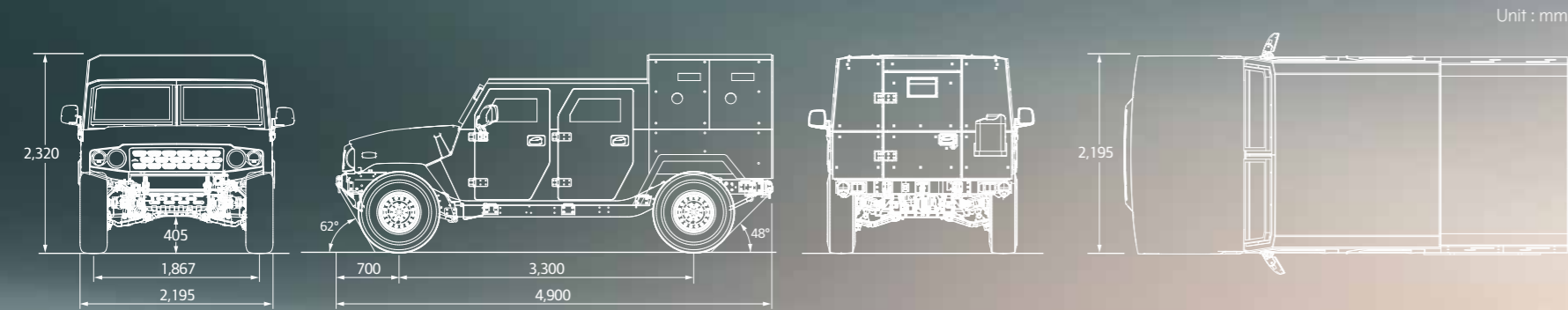

ENGINE & POWERTRAIN

- ▶ 225hp 3.0 LITER DIESEL ENGINE
- ▶ 8-SPEED AUTOMATIC TRANSMISSION

INSTRUMENT PANEL

- ▶ CENTRALIZED INSTRUMENT PANEL & MULTI-INFO DISPLAY
- ▶ AUDIO, NAVIGATION, HVAC CONTROL & REAR-VIEW MONITOR

PROTECTION

- ▶ BULLET : GLASS, DOOR & SIDE PANEL, DECK REAR PANEL
- ▶ MINE : FLOOR & DASH PANEL ▶ SHELL SPRINTER : ROOF

KM450

1 ¼ ton Cargo Truck

Multipurpose 4×4 Truck With the best off-road capability

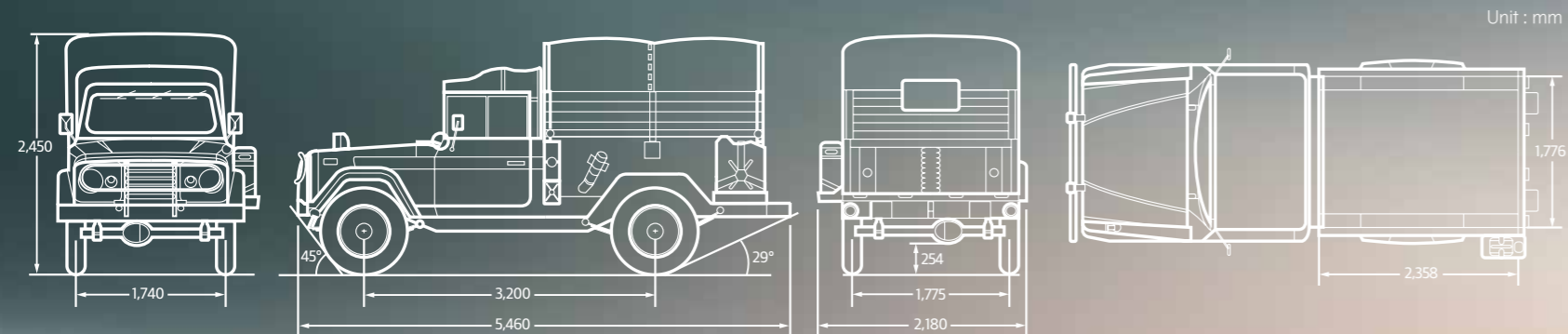

ENGINE & POWER TRAIN



- ▶ 139hp 4.0 LITER DIESEL ENGINE
- ▶ 5-SPEED MANUAL TRANSMISSION

UTILITY



- ▶ CANVAS FOR CABIN & CARGO
- ▶ WINDSHIELD FOLDING

CARGO BOX



- ▶ PAYLOAD : 2,500 kg
- ▶ SIZE : 6m³
- ▶ TROOP SEATS FOR 12 SOLDIERS



KM250

2 ½ ton Cargo Truck

Multipurpose 6x6 Truck
suited for various tactical missions

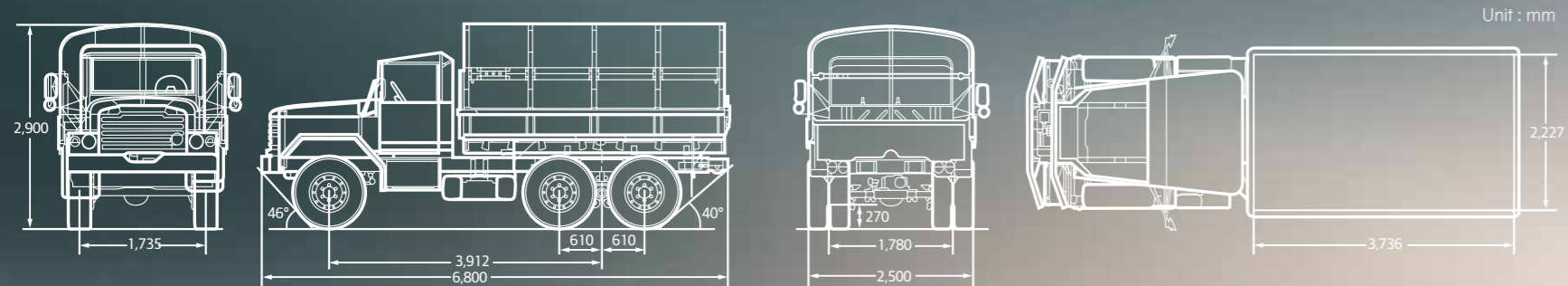

ENGINE & POWER TRAIN



- ▶ 6 CYLINDER 180hp DIESEL ENGINE
- ▶ 5-SPEED MANUAL TRANSMISSION

UTILITY



- ▶ CANVAS FOR CABIN & CARGO
- ▶ WINDSHIELD FOLDING

INSTRUMENT PANEL



- ▶ SIMPLE AND INFORMATIVE WITH SPEEDOMETER, TACHOMETER, AIR CLEANER SERVICE AND OIL PRESSURE INDICATOR

CARGO BOX

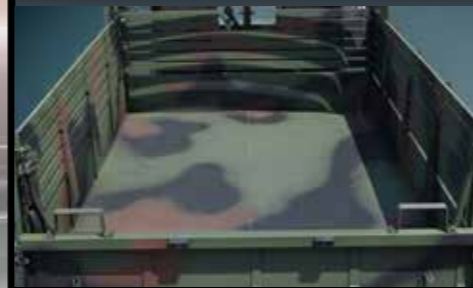

- ▶ PAYLOAD : 5,000kg
- ▶ SIZE : 13m³
- ▶ TROOP SEATS FOR 20 SOLDIERS



KM500

5 ton Cargo Truck

Multipurpose 6x6 Truck with high payload for the toughest missions

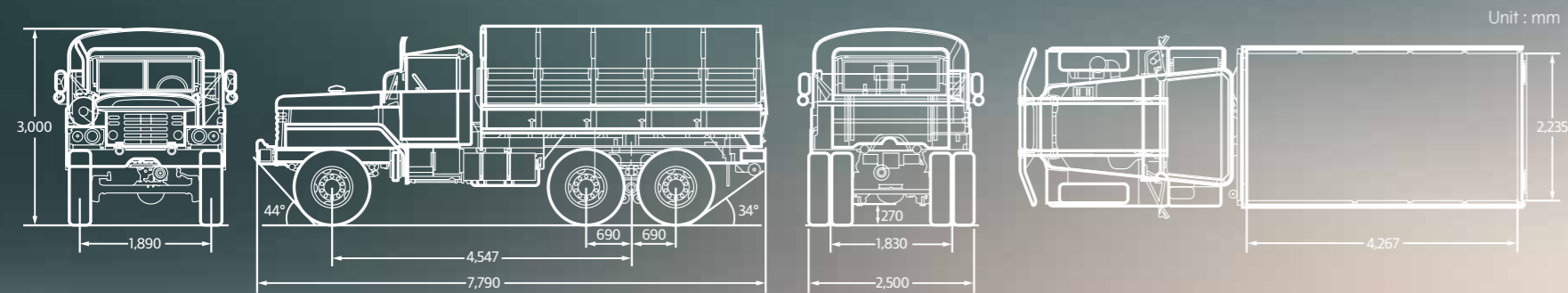

ENGINE & POWER TRAIN



- ▶ 6 CYLINDER 270hp DIESEL ENGINE
- ▶ 5-SPEED MANUAL TRANSMISSION

UTILITY



- ▶ CANVAS FOR CABIN & CARGO
- ▶ WINDSHIELD FOLDING

INSTRUMENT PANEL



- ▶ SIMPLE AND INFORMATIVE WITH SPEEDOMETER, TACHOMETER, AIR CLEANER SERVICE AND OIL PRESSURE INDICATOR

CARGO BOX



- ▶ PAYLOAD : 10,000kg
- ▶ SIZE : 15.6m³
- ▶ TROOP SEATS FOR 24 SOLDIERS



KLTV

KM450

KM250

KM500

KMTV

KMTV

Medium Tactical Vehicle

※ Under Development



KMTV Truck (4x4)



KMTV Truck (6x6)



Armored KMTV

Kia military vehicles in the World

Since we were designated as the sole manufacturer of military vehicle for Korean Armed Forces in 1976, we, Kia, are exporting military vehicles to all around the World.



Satellite Communication Equipment



Communication Relay Equipment



Water Tanker

Export Vehicles

Kia military vehicles are operated in Peace Keeping Operation by United Nations. Also, Kia vehicles have customers in more than 20 countries across the globe. Now, Kia is one of the most big global automakers who contributes to defense mobility and logistics.



Military Caravan



Police Cargo Truck



Rescue Vehicle



UN PKO Ambulance



Tractor



UN PKO Shop Van



UN PKO Cargo Truck



UN PKO Wrecker

Special Load Vehicles

Besides the basic models which we introduced from previous pages, we are manufacturing vehicles for special purposes.



Fire Direction Center



Communication Equipment

'The optimal performance to dominate the battlefield'

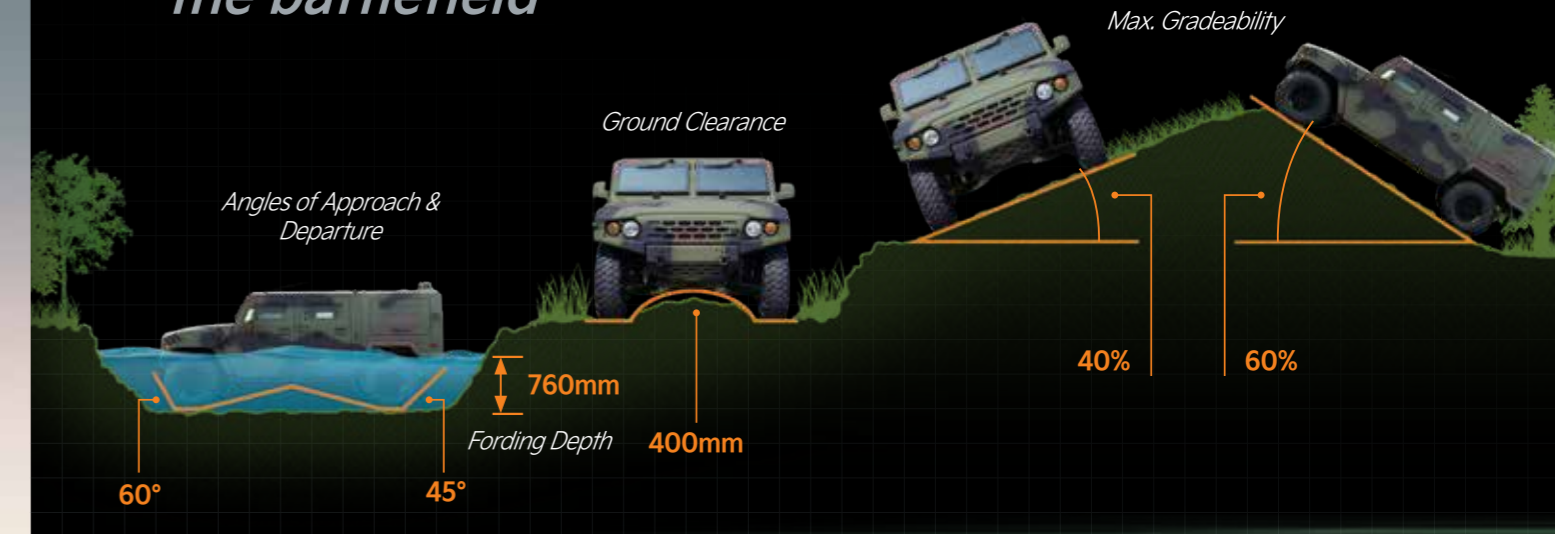

CAPABILITIES

'Overcoming all terrains over the world'

It is the driving performance and durability that only military vehicles have that can bring out the maximum tactical efficiency in any rough terrain and extreme weather conditions such as cold regions, wetlands and deserts along with bulletproof performance for crew protection. Kia has a full line up of cutting edge military vehicles that can offer the best performance in any operating environment and will continue to strive for improved performance in the future.

Environmental Adaptability



-32°C



43°C

Electro-magnetic Interference



MIL-STD



LINE-UP

KLTV Series



KLTV141 Bulletproof Command Vehicle



KLTV181 Bulletproof Personnel Carrier



KLTV143 Bulletproof Reconnaissance Vehicle



KLTV223 Cargo Truck

1 ½ TON Series



KM450 Cargo Truck



KM451 Ambulance



KM452 Shop Van



KM454 Shelter Cargo

2 ½ TON Series



KM250 Cargo Truck



KM255 Fuel Tanker



KM256 Water Tanker



KM258 Shop Van

5 TON Series



KM500 Cargo Truck



KM504 Expandable Van



KM508 Spare Parts Van



KM507 Decontamination Vehicle

New Medium Truck



KMTV Truck (4x4)



KMTV Truck (6x6)



Armored KMTV

※ Under Development

SPECIFICATIONS

KLTV181



KM450



KM250



KM500



Configuraion, Seating		4x4, 1+7	4X4, 1+1	6X6, 1+2	6X6, 1+2
Dimensions	Overall Length (mm)	4,900	5,460	6,800	7,790
	Overall Width (mm)	2,195	2,180	2,500	2,500
	Overall Height (mm)	2,320	2,450	2,900	3,000
	Wheel Base (mm)	3,300	3,200	3,912	4,547
	Tread:Front/Rear (mm)	1,867 / 1,867	1,740 / 1,775	1,735 / 1,780	1,890 / 1,830
	Ground Clearance (mm)	405	254	270	270
	Angle of Approach (°)	62	45	46	44
Weight	Angle of Departure (°)	48	29	40	34
	Curb Weight (kg)	4,700	3,150	6,500	10,000
Performance	Payload (kg)	1,000	2,500	5,000	10,000
	Gross Weight (kg)	5,700	5,650	11,500	20,000
	Max. Speed (km/h)	130	104	95	88
	Max. Gradeability (%)	60	←	←	←
	Cruising Range (km)	640	750	900	800
	Min. Turning Radius (m)	7.8	8.0	10.8	12.7
Engine	Fording Depth (w/o Kit) (mm)	760	←	←	←
	Model	S2	D4DA / D4DD	KK-7.4	D6AZ
	Type	V6-Cylinder	In-line 4-Cylinder	In-line 6-Cylinder	←
	Displacement (cc)	2,959	3,907	7,412	11,149
	Fuel	Diesel	←	←	←
	Max. Horsepower (hp@rpm)	225@3,200	130@2,900 / 139@2,900	180@2,900	270@2,200
	Max. Torque (kg.m@rpm)	51@2,200	37@1,600 / 38@1,600	51@1,600	98@1,400
	Transmission	Type	Automatic, 8-Speed	Manual, 5-Speed	←
Transfer Case	Number of Speeds	Part Time, 2-Speed	←	←	
Fuel System	Fuel Tank Capacity (ℓ)	80	106	208	295
Electric System	Voltage (V)	24	←	←	←
Tire	Type	315/85R16	36"-12.5R 16.5	9.00-20 8PR	11.00-20 12PR

※ All information and illustrations are based on data available at the time of publication and are subject to change without notice according to any further improvements or operational environments.

※ The specifications and features contained in this publication may inevitably be changed due to the improvement of product performance.
In addition, the content of this publication may differ from the actual product depending on the time of printing, application of optional features, printing, and other errors, so please contact your local Kia dealer for the most current information.

Kia Special Vehicle

KIA CORPORATION

12, Heolleung-ro, Seocho-gu, Seoul, 137-938, Korea

Homepage : <http://military.kia.com>

Email Address : KJAD@autos.hmgc.net

2110-DC-SW/GE-LHD



Movement that inspires